

# Raising Pheasants or Other Game Birds

Habitat Extension Bulletin

No. 33

*The demand for pheasant hunting has increased steadily through time, and there is now great interest in supplementing wild game bird populations with pen-raised birds. Pay-to-hunt game bird preserves are increasing rapidly, so many people are raising game birds for additional income. This publication outlines some general guidelines for raising pheasants, chukars, bob-white quail, and gray or Hungarian partridge. All four species are popular with sportsmen, but their specific needs require that the novice do his homework carefully before attempting to raise any of these species.*

Quality game birds are not difficult to raise with proper research and preparation. It is advisable to start small and learn the hard lessons early before making a large investment. If chicks are purchased, their cost is only 15 to 20 percent that of adult birds, but more time and specialized equipment are needed to successfully raise them. Buying eggs or keeping breeding stock adds more time and equipment to the process.

The least time-consuming option involves buying adult birds and raising them in holding pens. Initial costs are high, but labor costs are moderate, and death loss is low. Orders should

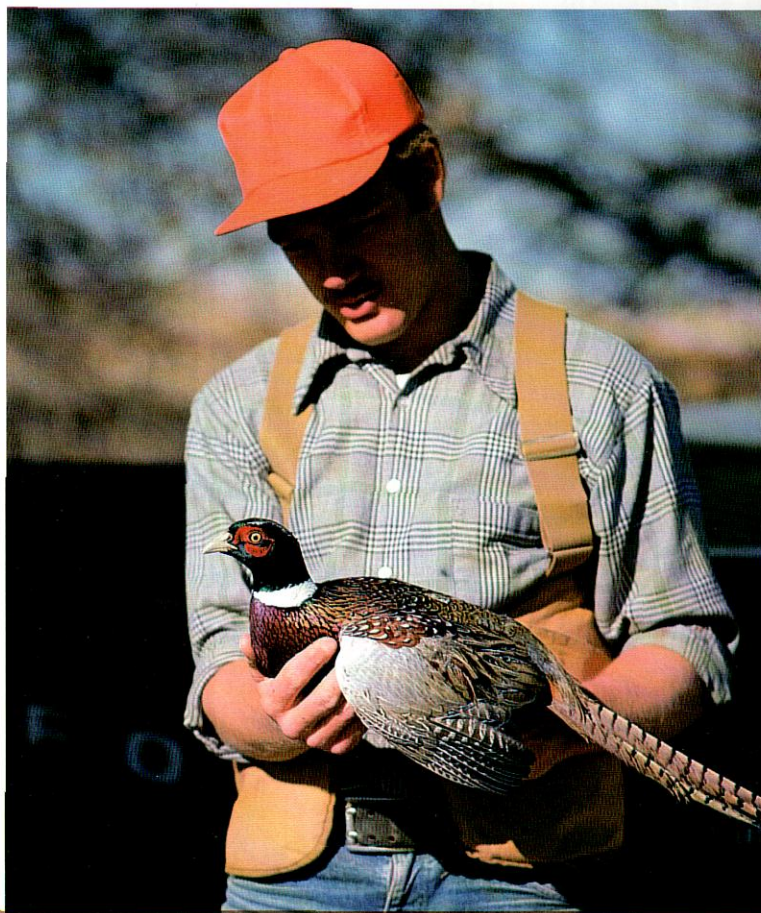

**Habitat Extension Services**



WYOMING GAME AND FISH DEPARTMENT



wire, brooders, and dozens of other items. Table 1 contains a list of some available literature. There are other good books, magazines, and catalogs available, but these will get you started. The two books listed are very good and contain valuable information on raising birds and operating a hunting preserve.

### **Legal Requirements of a Game Bird Farm**

#### *Possession Permit*

Wyoming statutes require that one of two permits be obtained before a person may legally raise or possess game birds. The first is the *possession permit* or "hobby permit." This permit is free and allows the holder to import and raise game birds for private use. However, the birds may not be sold, traded, or hunted. Persons wanting to raise

*The Wyoming Game and Fish Department's Springer bird farm (below) produces about 9,000 pheasants a year for release on surrounding state habitat units. The department's other bird farm near Downar produces about 13,000 pheasants which are liberated in northcentral Wyoming.*



be placed in early spring or summer as demand for adult birds is very high, and it is almost impossible to find healthy, low-cost birds at year's end. Most suppliers will hold birds for a deposit, but the longer they are kept, the higher the cost of the birds.

### **Game Bird Information and Material Sources**

When planning to raise game birds, you should obtain catalogs (Table 1) of game bird equipment suppliers and sources of feed supplies. As peak chick production begins in the spring, supplies of equipment are usually delayed due to increased demand, so it pays to plan well in advance. Supply catalogs furnish valuable information on incubators, brooders, and feeders as well as the capacity and capability of many models of bird-rearing equipment.

Novice game bird raisers always need a list of sources for detailed husbandry information, birds,

game birds for pets or personal food should obtain the possession permit.

#### *Game Bird Farm License*

In order to sell, give away, or trade eggs, chicks, adult game birds, or to release game birds, you must purchase a *commercial game bird farm license* for \$50.00 from the Wyoming Game and Fish Department. Applications and permit regulations are available from the Cheyenne office or your local game warden. The permit must be approved by your local game warden who will inspect your facilities to ensure proper and humane bird care.

#### *Health Certificates*

All wildlife (including eggs from game birds) entering Wyoming must be accompanied by an official health certificate from the state of origin. Health inspections must be performed by an accredited, licensed veterinarian in the state of



origin. The health certificate must be forwarded immediately to the Wyoming state veterinarian who, in turn, will forward it the chief game warden. Game birds obtained from an instate source do not have to be health inspected. The rules for importing wildlife should be fully understood, as violations of importation and health inspection laws involve federal agencies and the state veterinarian as well as the Game and Fish Department. Detailed information is available upon request from the Cheyenne office.

### Choosing a Game Bird

There are four popular game bird species that bird farms raise and release regularly: the ring-

necked pheasant, bobwhite quail, chukar partridge, and gray or Hungarian partridge. The easiest of the four to raise and the one which retains most of its "wild" properties is the ring-necked pheasant. Chukars are hard to keep wild; quail are sensitive to stress and disease, and huns are for the best professionals to raise. Wildness in birds makes for a better hunt, but wild birds have lower fertility rates and lower egg production. Cannibalism also increases.

### Ring-Necked Pheasant

Pheasants are not impressed by modern breeding facilities, and their genetics keep them wild and undomesticated. While the pheasant is the

Table 1 ADDITIONAL INFORMATION AND MATERIAL SOURCES

SOURCE	NAME	SUBJECT	ADDRESS
Book	<i>Shooting Preserve Management: the Nilo system</i> (1966) By E.L. Kozicky and J. Madson	An old but still valuable book on game bird preserves.	Ordered from book stores or the Winchester Div. Olin Corp. E. Alton, IL
Book	<i>Hunting Preserves For Sport or Profit</i> (1987) By E.L. Kozicky	New book with current subjects Highly recommended.	Order from book stores or the CKWRI Press., Kingsville TX
Magazine	<i>Gundog Magazine</i>	Good classified ads for birds and hunting preserves.	P.O. Box 343, Mount Morris, IL 61054
Magazine & Assoc.	<i>Wildlife Harvest</i>	Premier organization. Sources for birds and equipment. Stories devoted to raising game birds.	P.O. Box 2105, Cayce-West Columbia, SC 29171
Magazine	<i>Game Bird Breeders Gazette</i>	Good classified ad section and information about raising birds.	Allen Publishing Co., 1328 Allen Allen Park Dr, Salt Lake City, UT 84105
Catalog	G.Q.F. Manufacturing	Complete equipment line from incubators to scalders.	P.O. Box 1552, Savannah, GA 31498
Catalog	Stromberg's	Books, birds, equipment, and novelty items.	Box 400, Pine River, MN 56474
Catalog	Endurance Net	Netting for pens and material for dividers.	Box 128, Roebling, NJ 08554
Catalog	J.A. Cissel Manufacturing Company	Netting for pens and special types of shades and dividers.	P.O. Box 339, Farmingdale, NJ 07727
Catalog	Louis E. Page, Inc.	Welded wire and hardware cloth.	P.O. Box 2405, Littleton, MA 04160
Catalog	Valentine Equipment Co.	Pen fencing, nets and misc.	7510 S. Madison St., P.O. Box 53, Kinsdale, IL 60521
Catalog	Kuhl Corporation	Pen fences, equipment for raising and shipping birds.	P.O. Box 26, Flemington, NJ 08822-0026
Catalog	National Band and Tag Co.	Bands for birds.	P.O. Box 430, Newport, KY 41072



---

easiest game bird to raise, it must have certain simple needs met to survive in captivity. With ample room, high-quality food, water, and clean living space, pheasants can be raised successfully.

There are hundreds of game bird suppliers nationwide. Most are below average; some are good, and a few are excellent. Some breeders raise birds for meat and the birds are big, plump, poor fliers. Others raise hybrids that have lost their instincts, and still others raise sickly birds under crowded conditions. It is important to visit your bird source and talk with the owners and their customers and contract in advance for delivery. Remember that all game birds are not created equal, and their wildness and genetics are as varied as in humans.

*The ring-necked pheasant (immediately below) is the easiest upland game bird to raise successfully for a hunting preserve. Since this bird is also popular with hunters, it is a good starting point for a preserve operator who wants to gain experience with bird rearing. The chukar (lower right) is a strong flier and can be popular with clients, but it tames easily and is more difficult to raise than pheasants. The gray or Hungarian partridge (lower left) is difficult to raise in captivity and may not always perform well before the gun. It is a species best left to experts.*





---

### Chukar Partridge

The only similarity between chukars raised in pens and wild chukars is their feathers. Unlike wild birds, pen-raised chukars will stay put for long periods and not quickly leave a preserve like pheasants. These domesticated birds do not survive in the wild, having lost all instincts for avoiding predators and foraging. Chukars are family-oriented and can be released and recalled home many times on hunting preserves. Cannibalism is not a serious problem, nor is room as critical — two and one-half square feet per bird are adequate. Chukars require flight conditioning in large pens before release, and if kept isolated from all human activity, their wildness will be retained to some degree.

### Bobwhite Quail

There are many strains of bobwhite quail, some of which are very domesticated. Strong fliers must have their environment closely controlled from hatch to release. Birds isolated from people and pets behave more like wild birds. Even if only a few people and dogs occasionally visit the pens, the birds will lose their wildness. Bobwhites are often raised in pens with wire floors to reduce the incidence of disease.

Quail raised in open spaces seek out open spaces upon release. To have quail stay in cover, avoid predators, and provide better hunting, overhead cover should be in place. Birds held in the dark often stay out of full sunlight upon release and provide better hunting.

Quail are sensitive to stress. If they are fed the same food upon arrival as they ate at the producer's, this stress will be reduced. Bobwhites from individual flocks establish very strong social structures (pecking order). When flocks are mixed, this structure will be broken and stress increased resulting in death of many birds. When birds are purchased, you should request that they come from the same holding pens. If the supplier cannot do this, then have the crates from different pens marked and continue to keep the birds in separate pens. Quality bobwhites that are great fliers require more care than other game birds, so be prepared to give extra attention to these birds.

### Gray Partridge

Gray or Hungarian partridge are difficult to raise in captivity for a number of reasons. These include: their wild nature, incompatibility of breeding pairs, low egg production, and poor fertility. Huns must be raised in isolation from people, and until a producer is experienced in game bird raising, this sporting bird should be left alone. Hun breeders are constantly learning new tricks for raising these birds and would be good sources of information before production attempts are initiated.

### Mature Birds or Eggs?

Professional game bird breeders can produce tens of thousands of high-quality birds using high-tech incubators and automatic feeders for less cost than any small operator. While raising a few dozen birds is fairly easy and cheap, they will not supply a hunting preserve for long. If you can raise 5,000 pheasants a year, you may be able to compete with professional bird farms.

Game bird husbandry on a large scale requires you to act as a veterinarian, nutritionist, laborer, salesman, and bookkeeper. Unless you are willing to commit thousands of hours a year, it is better to buy high-quality birds and simply maintain them in holding pens until release.

### Mature Birds

Hunting preserves are becoming very popular and demand for birds is high in the fall, so you should determine your sources for birds months ahead of time and put a deposit on them to insure delivery. Plan on keeping birds in holding pens for a week or two so they will calm down and be less stressed upon release. Find out what feed the birds have been eating and use the same upon receiving the birds. The more the holding pens, including feeders and waterers, are like the producer's, the faster the birds will recover from shipping shock.

### Breeding Season and Procedures

Rooster pheasants should be separated when they start setting up territories to prevent serious battles. A warm spell any time after January is enough to trigger breeding activity. In confinement, a rooster pheasant can easily breed a dozen hens and probably more, but egg fertility could become a problem as the breeding season progresses. One mating will produce fertile eggs for an average of three weeks. Hen pheasants start laying about April 1, the number of eggs laid determined by their health and the amount of calcium available. A healthy hen with a good diet will produce 100 eggs a season, so not many breeders are needed to start a large flock.

### Care of Eggs

- Eggs can be hatched in incubators or set under domestic chickens but egg care before incubation is critical. The following rules will help you be successful:
  - Eggs should be collected daily and kept in a cool, humid place at 55 degrees F.
  - Very dirty, small, or deformed eggs should be discarded because hatchability will be much less than normal eggs.
  - Store eggs in cartons with the pointed, small end down and turn at least twice daily. Tilt the cartons at a 45-degree angle to prevent the yolk from sticking to the membranes inside the shell.
-



Eggs that have been in storage for more than ten days will probably have reduced hatchability, so carefully plan your egg setting to increase hatching success. Before setting eggs that have been stored at 55 degrees F., in either an incubator or under a brood hen, warm the eggs to room temperature to reduce the shock of going from the cool temperature to 100 degrees F.

Illustration 1: Nest box to use with brood hen has no bottom and latchable door.

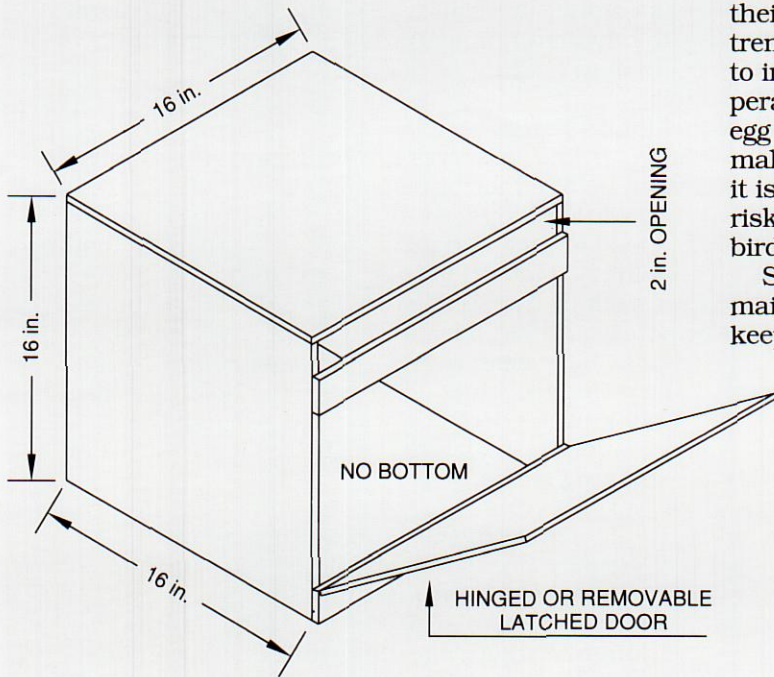

### Egg Incubation/Incubators

Vendors furnish valuable information on incubators as well as capacities and capabilities of their models. Commercial incubators are extremely efficient but must still be watched closely to insure a good hatch. Carelessness with temperature adjustments and egg turning can cause egg failure. After purchasing a new incubator, make a "test run" with fertile chicken eggs to see if it is operating correctly. This will reduce financial risks when the time comes to set valuable game bird eggs.

Still-air and forced-air incubators are the two main types. The forced-air types cost more, but keep temperatures more constant. The still-air

Illustration 2: Brood coop and rearing areas for hatchlings and brood hen.

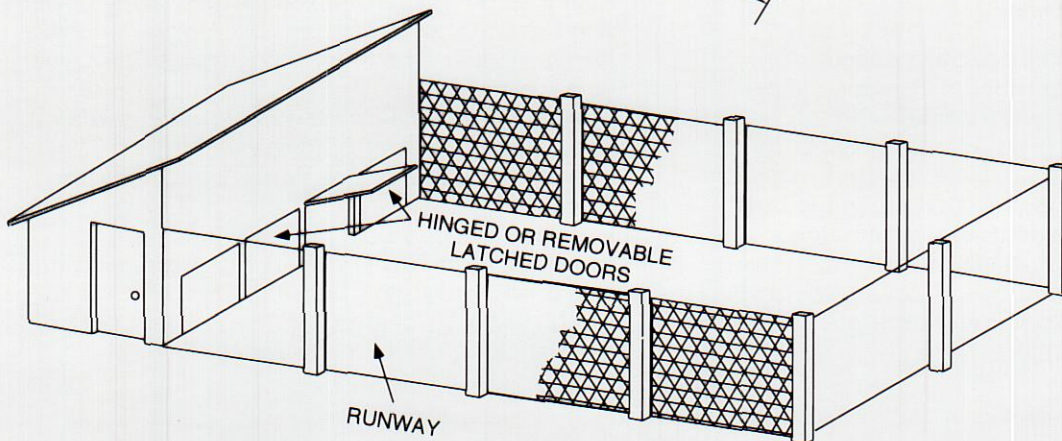
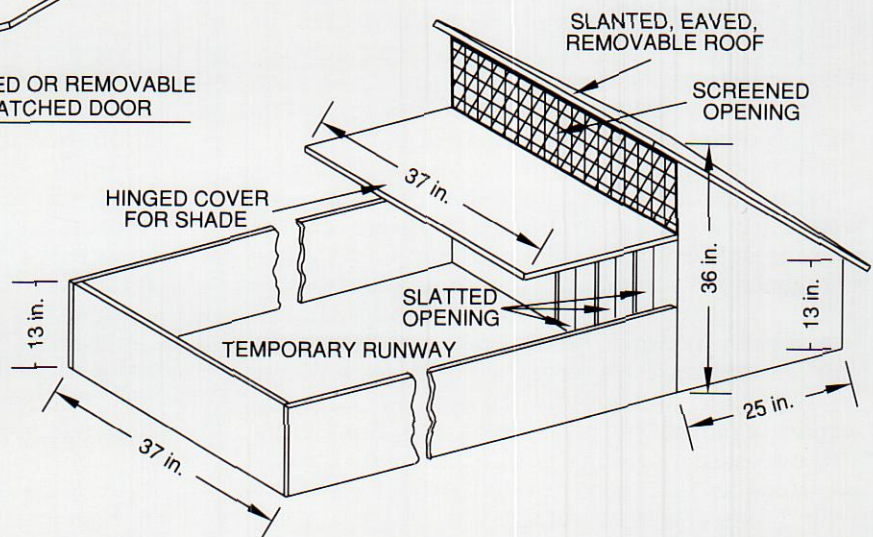



are small and temperature and humidity control are difficult. Incubators containing trays should have all trays left in the incubator whether there are eggs or not to maintain temperatures. Temperature settings of 100 degrees F. for forced-air and 103 degrees F. for still-air are usually good starting temperatures.

Cleaning and disinfecting incubators are the first steps to hatching success. Temperature and humidity control are also critical. Constant room temperature is a must to keep the incubator properly adjusted. Each brand of incubator will have specific instructions included, but your experience will be just as important. In Wyoming, dry conditions make eggs, especially quail eggs, very hard to hatch so humidity control is critical.

If the incubator does not have an automatic egg turner, eggs should be turned daily by hand to keep the shell membranes from sticking to the shells. Two days before hatching, the eggs should be placed on the wire floor of the incubator and left unturned. The following list gives the incubation periods for some game birds.

Pheasant	23-26 days
Chukar Partridge	23-24 days
Bobwhite Quail	23 days
Hungarian (gray) Partridge	23 days

After hatching, chicks should be transported to a brooder. Commercial brooders are available for reasonable cost. For large numbers of chicks, gas-operated brooders are the most efficient, but heat lamps have raised many broods successfully, though temperature control is difficult. The brooder, water, and feeders should be warmed for 24 hours before chicks are introduced. Chicks will slowly learn that food is in the feeders, so feed should be liberally spread on the floor of the brooder.

#### *Egg Incubation/Brood Hens*

For small operations, brood hens will easily incubate and raise chicks. Each brood hen will need a separate nest box and rearing pen. Bantam crosses make the best brood hens, while scaly leg chickens such as leghorns are unsuitable. Rhode Island reds or purebred bantams will work as brood hens but not as well as cross-bred bantams. Small hens can sit on eight to ten eggs and the larger birds will sit on ten to 15 eggs. Allow hens to sit on their own eggs and then move them after dark to the nest box containing game bird eggs. Give each brood hen a nest box 16 inches square with a latching door on one side. Dirt bottoms provide better moisture and attract few lice, and a small depression lined with dry grass will provide the hen with an ideal nest area. (Illustration 1) has diagrams of brood boxes and rearing facilities. The hen should be locked in the nest box for 24 hours to calm and attach her to the nest box and eggs. Brood hens compete for chicks

when different broods are raised together, and the competition is bad for the chicks, so keep broods separated. Hens that will not voluntarily sit on their eggs need to be locked in the box and let out for less than 30 minutes each day to eat and exercise.

A day after hatching, the chicken and chicks should be transferred to the brood coop (Illustration 2) which should have a bottom of clean straw, sand, or wire. The coop needs to be cleaned daily of hen droppings so the chicks will not eat them. The brood coop should provide one-half square foot of space per chick, with slats in the front to restrain the hen while allowing the chicks into the runway to exercise. Turkey starter should be placed outside the slats where the hen can reach it and teach the chicks how to eat. Water should be available for both the hen and chicks;



*The first egg in a clutch of pheasant eggs pips about 24 days after the hen began incubation. Within 24 hours, the chicks are hatched, dried and ready to leave the nest. Hatching eggs is a more complex process than it seems — matching the hen's performance takes regular attention and knowledge.*



Illustration 3: A flight pen (right) should allow 15 to 25 square feet of space per pheasant. The roof should be well supported so that it can survive a wet snow, but the support posts should be far enough apart to allow a small tractor to pass — 12 feet is usually adequate. A shelter pen (upper right corner) provides the birds with some refuge from bad weather.

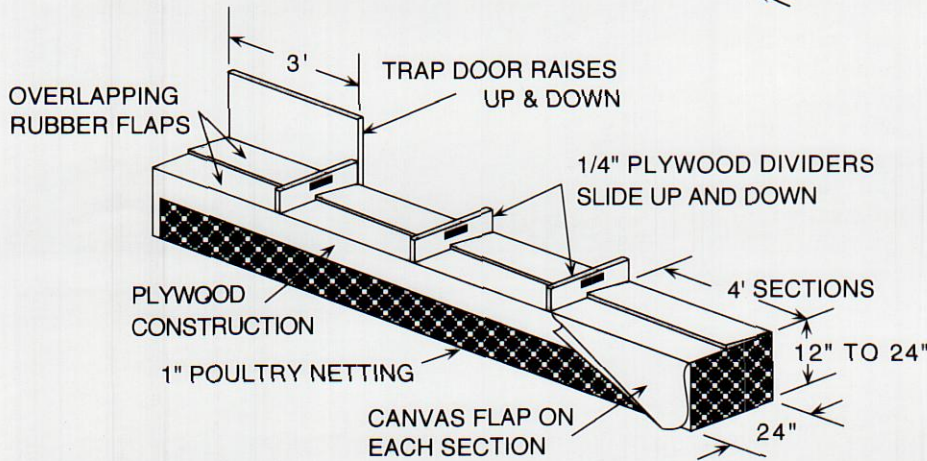
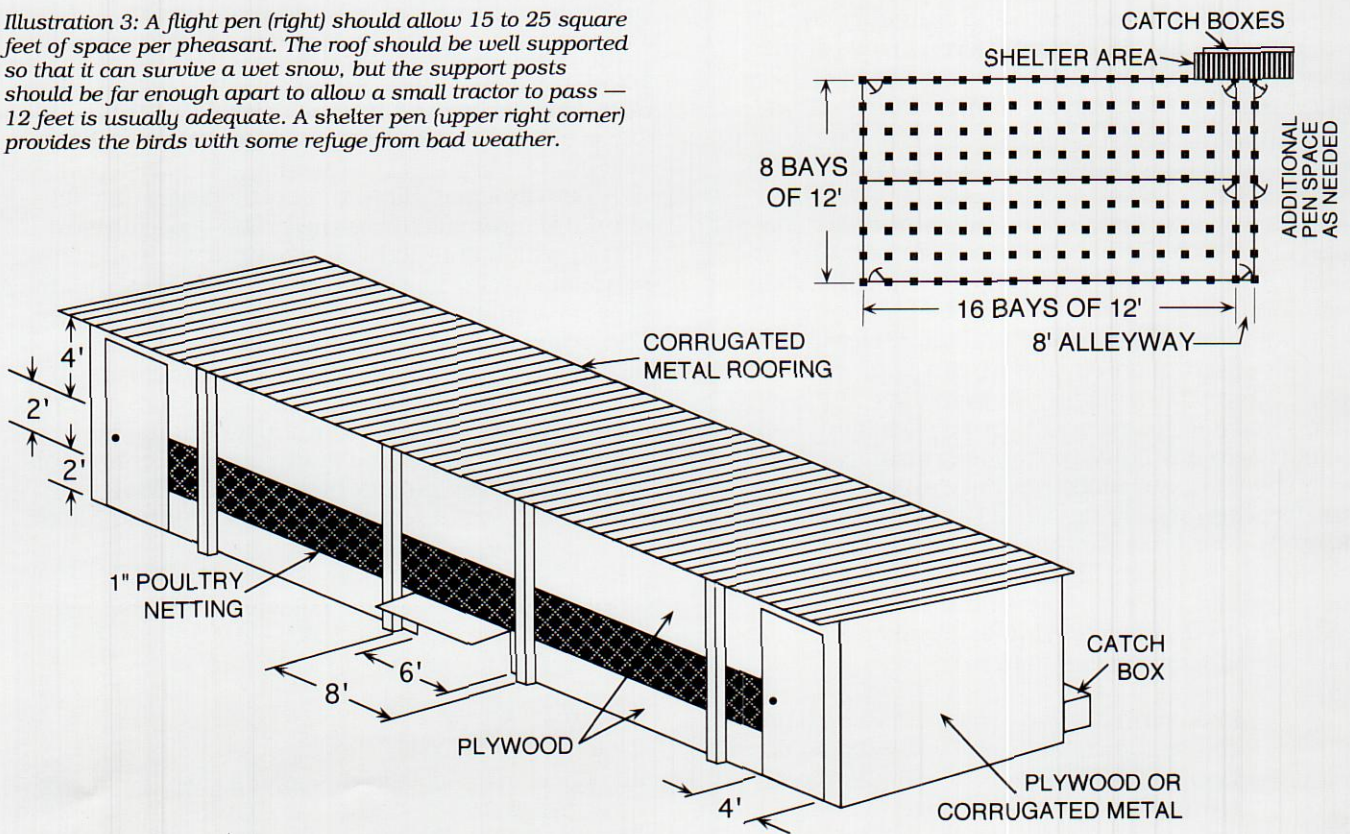

This diagram of a pheasant shelter (above) shows its plywood sides with a two-foot-high gap for ventilation. This gap is covered with one-inch poultry netting. The trap door in the center gives pheasants access from the holding pen.

Illustration 4: Catch boxes (above) allow the operator to trap pheasants for release with a minimum of disturbance.

Illustration 5: Catch boxes are arranged in a row along the back side of the shelter. Pheasants enter from a single trap door on one end and file down through the catch boxes.

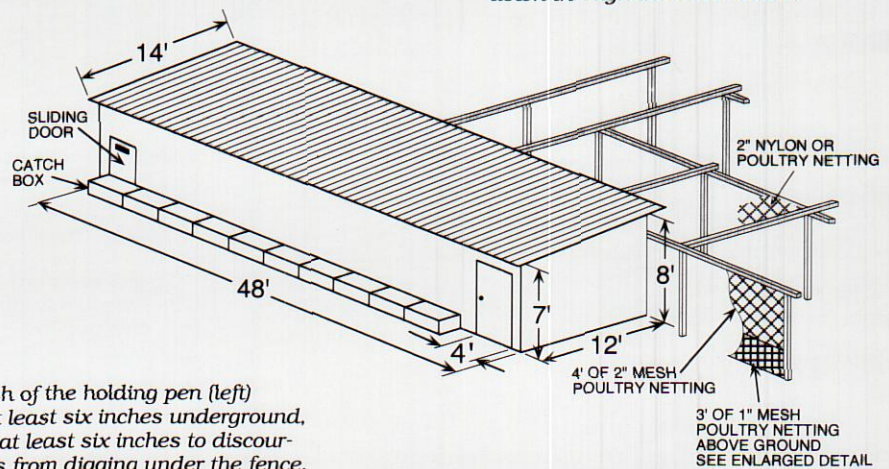

The wire mesh of the holding pen (left) should run at least six inches underground, then fold out at least six inches to discourage predators from digging under the fence.

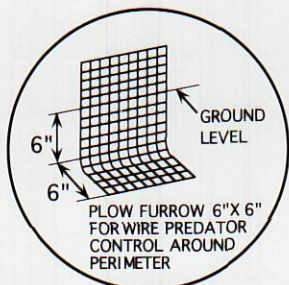



make sure the chicks can reach the waterers. Some hens will abandon chicks so they should stay confined at least until the chicks have most of their feathers at four to six weeks old. Chicks are sensitive to cold until they are older than six weeks, so a warm, dry environment must be provided.

### Feeding

Fresh water should be present at all times, since stagnant, dirty water is an invitation for disease.

**Chicks** — Feed turkey starter or game bird starter free choice from one day until eight weeks old. Green, succulent vegetation is a good addition to the diet; if absent from the pens, cut and feed this type of vegetation. Green cut alfalfa is loved by chicks and will help produce quality birds.

**Young birds** — Feed turkey or game bird grower from eight weeks to maturity.

**Maintaining adult birds** — Scratch grain containing corn, milo, barley, or wheat works well. Alfalfa hay is loved by birds in the winter and is a good food supplement.

**Breeders** — A high-protein turkey or game bird breeder feed should be started one month before normal egg production and continued through the breeding season. Fresh cut grass and alfalfa are a good addition to the breeder ration.

### Cannibalism

Preventing cannibalism is easier and cheaper than curing it. Poultry naturally peck at each other, and over-crowding magnifies this trait. Older chicks tend to peck younger birds, so housing different age groups together can trigger cannibalism. Improper heat in brooders will also add to the birds' urge to cannibalize. Signs of cannibalism include tail loss or mutilation. Providing ample space for birds at feeders, waterers, and in pens may alleviate this problem. Herbaceous cover grown inside the pens and perches for picked-on birds will add to the birds' safety.

To eliminate cannibalism in young birds, chicks should be brooded in subdued, red light. When pens are small, blinders (specs) or mouth bits will permit an increase in the number of birds, but the disease risk will also increase.

### Pens

There are a few simple rules to remember when designing pens for game birds that will pay off many times over if followed.

1. NEVER build pens where domestic poultry have been in the previous two years. Diseases that poultry are immune to such as coccidiosis (a protozoa that lives in the soil) are deadly to game birds. This organism can live in the soil for two years, and most game birds do not have the resistance to it that chickens have. Domes-

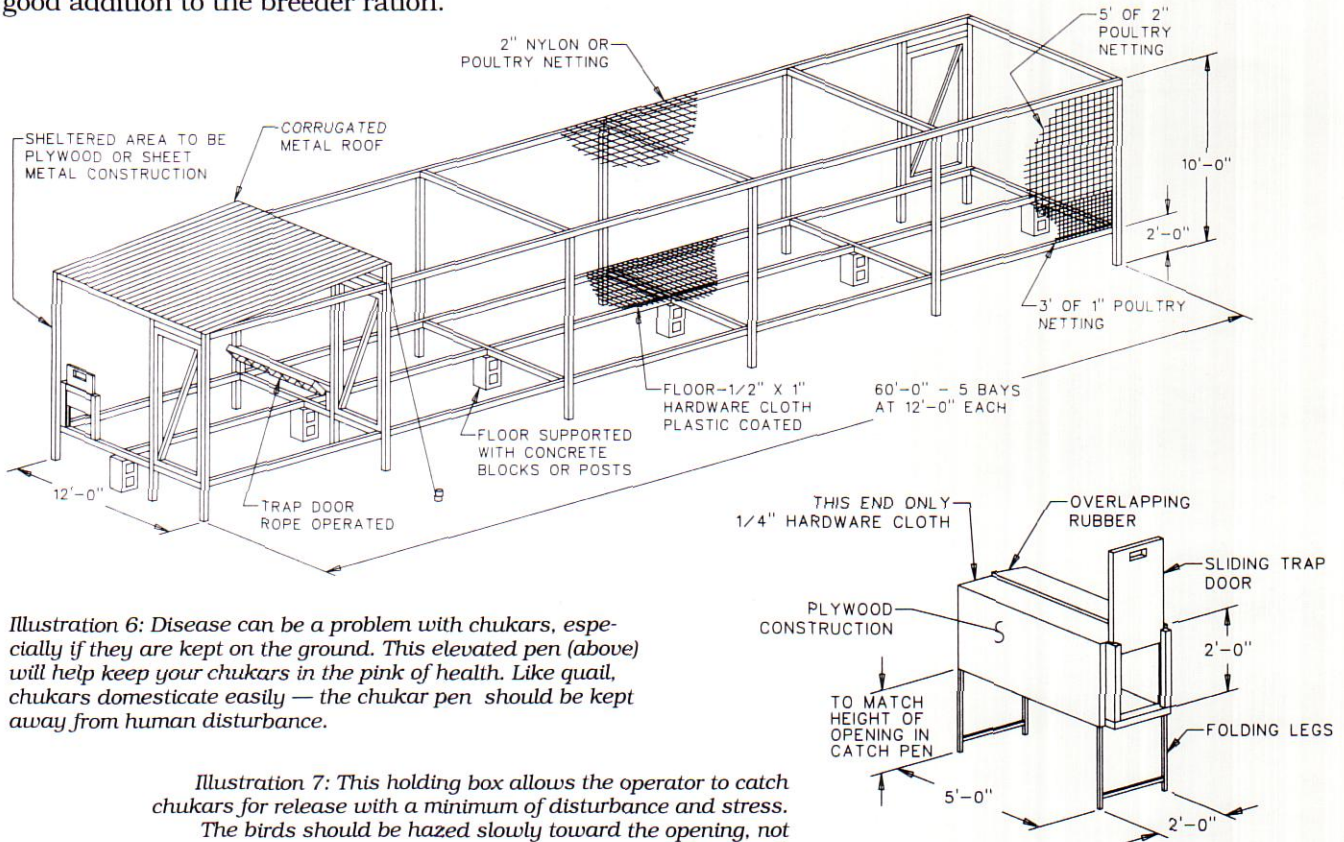

Illustration 6: Disease can be a problem with chukars, especially if they are kept on the ground. This elevated pen (above) will help keep your chukars in the pink of health. Like quail, chukars domesticate easily — the chukar pen should be kept away from human disturbance.

Illustration 7: This holding box allows the operator to catch chukars for release with a minimum of disturbance and stress. The birds should be hazed slowly toward the opening, not driven hard.

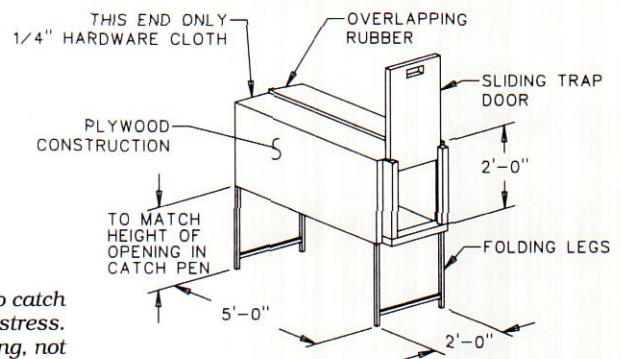
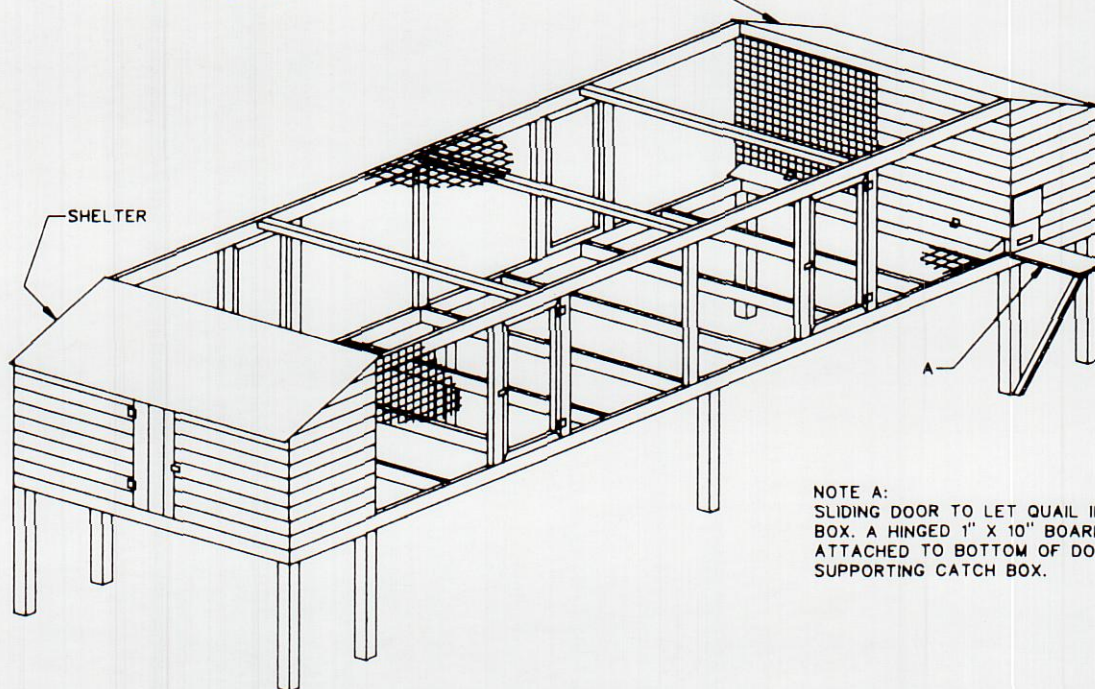
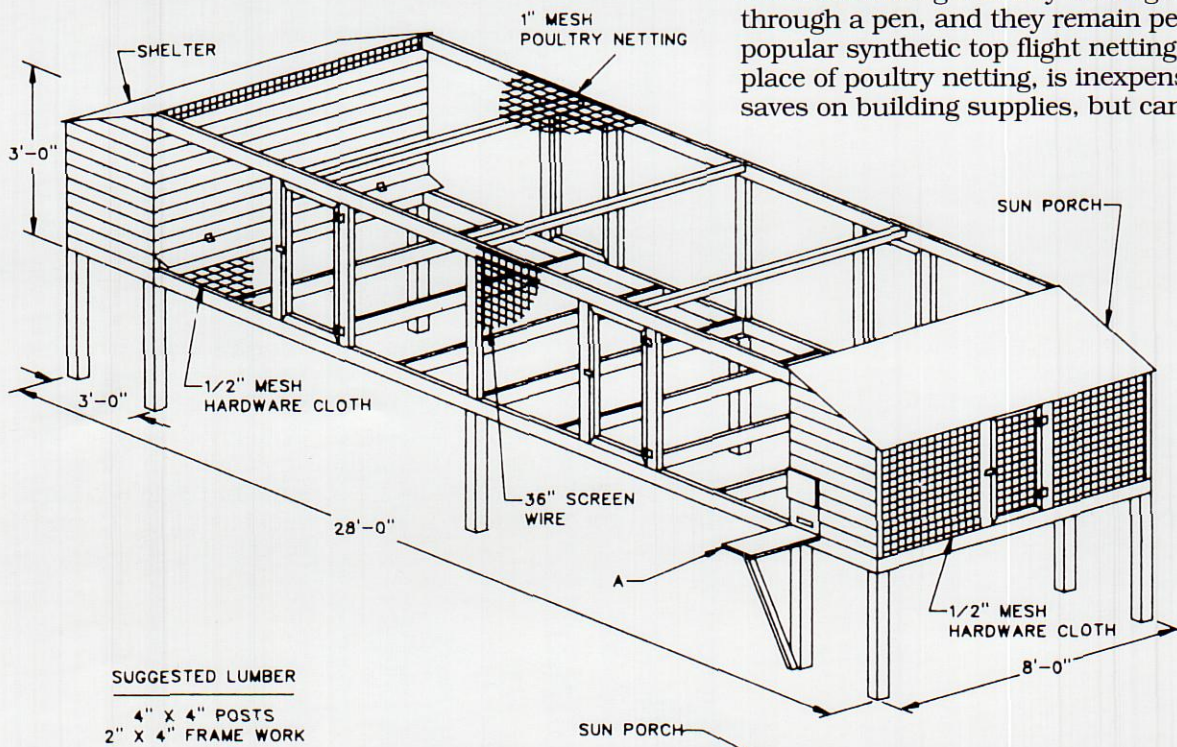



Illustration 8: This quail holding pen is used at Winchester Arms' demonstration hunting preserve in western Illinois. The pen is secluded on the edge of a patch of timber which affords some protection from wind and weather. It is also isolated from people, a vital precaution since quail tame very easily.

tic rabbits and cattle also can have coccidiosis, so it is wise to build pens where the least chance of infection exists. Pens can be built on fresh, clean ground or raised above the ground on wire for species other than pheasants. Even the best pens should be rested to let the sun and weather purify the ground.

2. Predators such as skunks, raccoons, owls, cats, and dogs all love to kill pheasants, and some or all of these will test pens for durability each year. Skunks or raccoons will kill a hundred adult birds a night if they can dig under or claw through a pen, and they remain persistent. The popular synthetic top flight netting, used in place of poultry netting, is inexpensive and saves on building supplies, but can be torn



NOTE A:  
SLIDING DOOR TO LET QUAIL INTO CATCH BOX. A HINGED 1" X 10" BOARD 2' LONG IS ATTACHED TO BOTTOM OF DOOR FOR SUPPORTING CATCH BOX.



easily by predators. An electric wire around the top of the pen will help protect the birds if synthetic top netting is used.

3. Pens cannot be too big. (See Appendix). Birds with long tails and strong wings need room to grow and fly. The most successful bird farms use large pens to raise birds that closely resemble wild birds in color and size.
4. Pens cannot be too sanitary. Bird farms that raise birds in filth are seldom in business for long. Good sanitation will pay for itself.

Weather conditioning of birds in flight pens is essential for survival upon release. Oil glands need to be developed to protect feathers against moisture.

### Pen Design

Pens that are wide enough to accommodate small tractors and implements will assist the manager with sanitation and planting cover crops. Adult birds require a minimum of 15 square feet per bird with 25 square feet per bird being ideal. If blinders are kept on adults, the required space can be reduced. A catch pen and shelter are needed at one end. Pens at the Wyoming Game and Fish Department's rearing facilities are good examples of efficient rearing pens. Illustrations 3, 5, 6 and 8 have modified diagrams of department bird-rearing facilities. Weeds and cover crops that will be found by the birds upon release are planted and encouraged in the runways to supply shelter and additional food sources. If sorghum is planted in food plots on the release site, plant it inside the pens. Birds that learn to use cover in the pens will use it upon their release. Game birds raised in the open without overhead cover go to open areas when released and usually run rather than fly.

Department pens (Illustrations 4 and 7) have a shelter at one end and all bird runs lead into a catch area. It is possible to catch birds by hand or with a net, but the stress to the birds' health and plumage, not to mention the handlers, can be excessive. A well-designed catch pen will pay for itself many times by reducing the number of injured birds. Many of the best bird farms have a dimly lit shelter area at one end of the holding pens where birds can be left overnight before a morning release. Additional stress on the birds is reduced since they are easily herded into catch boxes. This area can be modified in the spring for use as a chick brooding area.

Birds that are to be released should be transferred from the catch boxes to release crates. Crate design is not important as long as the crates are well-ventilated and only about seven inches high to prevent birds from piling on top of one another.

### Health

Many of the diseases and parasites that plague game birds in other areas of the country do not thrive well in Wyoming because of the dry climate. Pheasants have surprisingly good immunities to many diseases but still are affected by some. Clean pens, food, and water are the best ways to prevent disease, but even the most careful operator will occasionally lose birds. A veterinarian should be consulted to learn of treatments and prevention of bird diseases.

New birds should be quarantined for a few days to insure that they are disease free. Even a qualified health inspection is no guarantee of clean

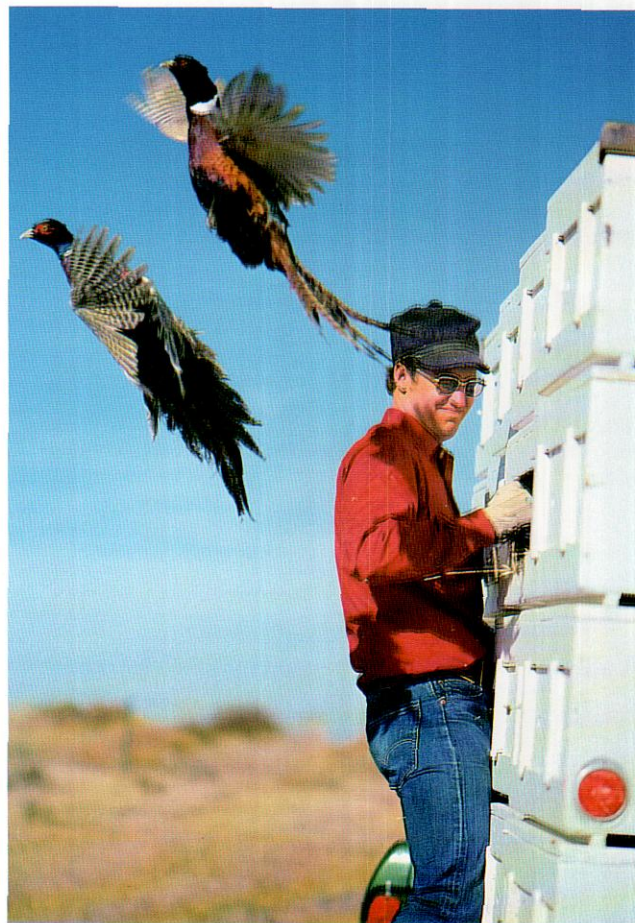

*High-quality pheasants like these are no accident. This manager has been careful not to overfeed these birds, and he has planted dense cover on the floors of his holding pens to discourage the pheasants from picking at each other. The result? Strong fliers with beautiful plumage and an affinity for natural pheasant habitat.*



birds. Rodents, sparrows, and starlings are a potential source of parasites and filth and should be controlled. They will also contaminate and eat as much food as you allow. There are commercial traps available for trapping these nuisance animals.

Feeders and waterers should be cleaned regularly with soap and hot water. Before introducing birds to pens or brooders, thoroughly clean and disinfect these facilities with a commercial disinfectant. An inexpensive but extremely effective disinfectant is diluted bleach used in a weed sprayer.

Birds will inevitably contract lice and mites. Be prepared by supplying a dusting box containing sand mixed with an effective insecticide such as five percent Sevin dust. Each time a bird is handled, a dusting with insecticide should be standard procedure to help insure healthy birds. Lice infections are deadly to young chicks and can quickly kill a brood.

### Bibliography

Kozicky, E., and J. Madson. 1966. *Shooting Preserve Management - the Nilo System*. Winchester Div., Olin Corp., E. Alton, IL 311pp.

Kozicky, E.L. 1987. *Hunting Preserves for Sport or Profit*. Caesar Kleberg Wildlife Research Institute. CKWRI Press. Kingsville, TX 200pp.

Montana Department Fish, Wildlife and Parks. *Montana's Pheasant Enhancement Program*. Helena, MT.

### Appendix

Adapted from "Hunting Preserves for Sport or Profit" By Edward L. Kozicky.

#### Pheasant Flight Pens

A pen 180 feet long and 24 feet wide (4,320 square feet) is suitable for holding 150 to 200 mature ring-necked pheasants.

A spacing of 12 feet between poles will adequately support a two-inch nylon netting roof. Nine-gauge wire is suitable for top bracing between poles.

Around the sides of the pen, start with three-foot, 18-gauge, one-inch galvanized mesh wire. Plow a fur-

row around the outside perimeter of the pen about six inches deep and six inches wide. Bend the lower foot of the one-inch mesh wire into the furrow in a 90-degree "L" shape and cover it with dirt to help keep predators out. For the remainder of the sides (five feet) of the pen, use 18-gauge, two-inch galvanized mesh wire, and hog ring the two sections of wire together. Cover the top of the pen with two-inch nylon netting. Do not stretch the wire or nylon netting too tightly. If the wire is loose, it will help absorb the shock of flying pheasants, and a loose nylon netting on the top of the pen will stretch with the weight of snow. The posts should be about ten feet long. Set them three feet deep, providing an inside height of seven feet in holding pen. Use braces to hold the outside posts upright, especially the corner posts.

The sides and top of the shelter area should be sufficiently braced with wood boards to attach plywood and/or sheet-metal or aluminum roofing. The front part of the shelter area (the side inside the holding pen) should be covered with one-inch poultry netting except for the lower 30 inches. The bottom 30 inches should contain a swinging gate operated by ropes to admit pheasants into the shelter. When pheasants are needed, they can be herded into the shelter and the gate dropped. Pheasants within the shelter area can either be caught by hand or with a poultry net. A better technique involves constructing a catch box on the outside of the shelter area.

#### Rearing Area

The nest box and brood coop are kept inside the rearing shed which can be a converted out building. As the chicks grow, they can be let into the outside pen to further develop. Allow seven to 12 square feet per chick. During bad weather, the chicks can be locked in the rearing shed to keep them dry and warm.

*Written by Doug Samuelson of the Wyoming Game and Fish Department through the Wyoming Cooperative Fish and Wildlife Research Unit.*

*Illustrations 3 through 8 courtesy of "Hunting for Sport or Profit" by Edward L. Kozicky.*

*This publication is one in a series of habitat extension bulletins produced by the Wyoming Game and Fish Department. Call 1-800-842-1934 for additional information or assistance.*